

Data sheet

Colibri® Electric expansion valves

Type ETS 12C, ETS 24C, ETS 25C, ETS 50C, ETS 100C



ETS Colibri® is an electric stepper motor valve. The valve has been designed for precise liquid injection into evaporators for air conditioning and refrigeration applications.

The valve in-line design includes balanced cage and slider assembly operated by the direct driven motor technology. This ensures solenoid tight shut-off in both flow directions, thus providing smooth operation of the system.

The valve incorporates a powerful bi-polar motor which precisely controls flow regulation. ETS Colibri® valves are compatible with electronic control solutions from Danfoss and other manufacturers.

Applications:

Air Conditioning

- Chillers, heat pumps
- Roof top and ducted split systems
- VRF and other split systems
- Close control cooling

Refrigeration

- Cold Rooms, Food retail and Transport

Features / Benefits

Precise control of liquid injection

- Optimum utilization of the evaporator
- Increased energy efficiency and COP
- Improved overall system performance

Linear Flow characteristic

- Repetitive operation of the valve at all conditions

Balanced cage design

- Higher MOPD and MWP
- Easily fits in various application and operating conditions

Direct driven valve motor technology

- Powerful motor that guarantees precise flow control and increased energy efficiency of the system

Supports variety of refrigerants, approved for oil free applications

- Wide application scope

Fast opening/closing time of 2.5 seconds

- Quick reaction to the operating condition
- Minimizes the risk of liquid refrigerant flowing into the compressor at shut down and low pressure cut out at start up

Solenoid tight shut-off

- Prevents migration of the refrigerant during stand-still
- Reduced complexity by reducing number of components in the system

Sight glass / moisture indicator

- Fast troubleshooting during system diagnostics

Compact, lightweight and in-line design

- Flexible and easy integration in any system

Bi-metal connectors

- Fast and improved brazing process - no wet wrap needed

Stainless construction

- Internal and external corrosion resistant

Fully hermetic laser welded design

- Hermetic valve in accordance to EU F-gas Regulation EU 517/2014
- No external leakage which saves cost on maintenance and refrigerant loss
- Protecting the environment and climate

Manufactured according to ISO/TS16949

- Second – to – none quality and reliability

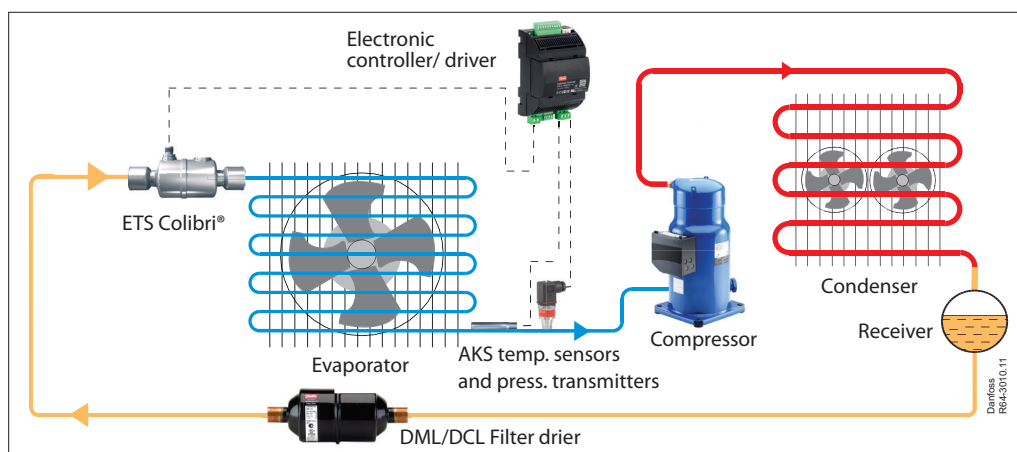

For more info

Application

Approvals: ETS Colibri®

 CE, REACH, UL, LLC CDC EURO TYSK, EAC
 Applied for: ATEX II 3G Ex nA T6

Technical data

Compatible refrigerants	R410A, R404A, R507, R134a, R407A, R407B, R407C, R407F, R32, R290, R1234ze, R1234yf, R449A, R449B, R452A, R1270, R600, R600a, R22, R23, R227, R417A, R444B, R447A, R448A, R454B, R422A, R422D, R427A, R502, R513A, R413A, R438A, R450A, R455A, R454C, R454A, R452B.
Refrigerant oil	POE, PVE, All mineral oils, ester oils and supports oil free
Complies with PED	Yes, Fluid group 2, article 4 paragraph 3 for all ETS Colibri Yes, Fluid group 1 (flammables), article 4 paragraph 3 for DN < 25 (inner bore) For details see ordering form
MOPD	40 bar / 580 psi
Max. working pressure PS/MWP	50 bar(g) / 725 psi(g)
Refrigerant temperature range (measured at the inlet of the valve)	-40 – 70 °C / -40 – 158 °F
Ambient temperature	-40 – 70 °C / -40 – 158 °F
Capacity control range	10% - 100% of total opening degree
Initial opening	5% = 30 full steps
Environmental transport/storage temperature and humidity	Max. +75 °C / +167 °F, Humidity: <100% RH
Material of construction	Body: Stainless Steel / Connector: Bimetal (stainless steel and copper)
Sightglass / moisture indicator	Type N moisture indicator

Electrical data

Motor enclosure	IP67
Stepper motor type	Bi-polar - permanent magnet
Step mode	Microstepping (recommended), 2 phase full step or half step
Phase current	800 mA peak / 600 mA RMS
Holding current	No permanent holding current needed. Max. 20% permanent holding current allowed with refrigerant flow through valve For optimal performance, driver should keep 100% current on coils 10ms after last step
Phase resistance	10 Ω ±10% at +20 °C / +68 °F
Inductance	14 mH ±25%
Duty cycle	100% possible, requiring refrigerant flow through valve Less than 50% over 120 sec period recommended
Nominal Power consumption	7.44 W RMS at 20 °C (total, both coils)
Total number of full steps	600
Step rate	Current control driver: a. Step type: Microstep (1/4 th or higher): 240 full steps/sec. recommended b. Step type: Full step or Half steps: 240 full steps/sec. recommended Emergency close : 240 full steps/sec. OEMs with 3rd party controller, please contact Danfoss
Step translation	0.0167 mm / step
Full travel time	2.5 at 240 steps / sec
Opening stroke	10 mm / 0.4 in.
Reference position	Overdriving against the full close position
Overdriving performance	1% (6 full steps) Overdrive is recommended for optimum performance 628 steps in closing direction recommended for initialisation Overdriving in open position not recommended
Electrical connection	according to EN 61076-2-101
Compatible controllers / driver	Danfoss EKE 1A, EKE 1B, EKE 1C, MCX061V, MCX152V Certain third party controllers / drivers. Contact Danfoss for details

Ordering



Type	K _v value [m ³ /h]	C _v value [gpm]	Rated capacity ¹⁾										Connection		Code no. single pack	Code no. 1-pack 12 pcs.		
			R410A		R407C		R1234ze		R134a		R290		ODF × ODF (A × B)	[in]			[mm]	
Without sight glass																		
ETS 12C	0.8	0.9	91.4	26.4	83.0	23.9	46.8	13.5	59.4	17.1	79.7	23.0	1/2 × 1/2	-	034G7500	034G7510		
	0.8	0.9	98.1	28.3	89.1	25.6	50.3	14.5	63.7	18.4	85.6	24.7	5/8 × 5/8	16 × 16	034G7501	034G7511		
	0.8	0.9	105	30.2	95.1	27.3	53.6	15.4	68.0	19.6	91.3	26.3	7/8 × 7/8	22 × 22	034G7502	034G7512		
ETS 24C	1.3	1.5	129	37.3	117	33.7	66.2	19.1	83.9	24.2	113	32.5	1/2 × 1/2	-	034G7900	034G7910		
	1.3	1.5	138	39.7	125	35.9	70.4	20.3	89.3	25.7	120	34.6	5/8 × 5/8	16 × 16	034G7901	034G7911		
	1.3	1.5	170	49.2	155	44.5	87.3	25.1	111	31.9	149	42.8	7/8 × 7/8	22 × 22	034G7902	034G7912		
With sight glass																		
ETS 25C	1.3	1.5	170	49.2	155	44.5	87.3	25.1	111	31.9	149	42.8	7/8 × 7/8	22 × 22	034G7602	034G7612		
ETS 50C	2.4	2.8	323	93.3	294	84.5	166	47.7	210	60.5	282	81.3	7/8 × 7/8	22 × 22	034G7700	034G7710		
	2.4	2.8	323	93.3	294	84.5	166	47.7	210	60.5	282	81.3	7/8 × 1 1/8	22 × 28	034G7701	034G7711		
	2.4	2.8	323	93.3	294	84.5	166	47.7	210	60.5	282	81.3	1 1/8 × 1 1/8	28 × 28	034G7702	034G7712		
	2.4	2.8	323	93.3	294	84.5	166	47.7	210	60.5	282	81.3	1 1/8 × 1 3/8	28 × 35	034G7703*)	034G7713*)		
ETS 100C	5.0	5.8	635	183	577	166	325	93.7	413	119	554	160	1 1/8 × 1 1/8	28 × 28	034G7800	034G7810		
	5.0	5.8	635	183	577	166	325	93.7	413	119	554	160	1 1/8 × 1 3/8	28 × 35	034G7801*)	034G7811*)		
	5.0	5.8	635	183	577	166	325	93.7	413	119	554	160	1 3/8 × 1 3/8	35 × 35	034G7802*)	034G7812*)		
	5.0	5.8	635	183	577	166	325	93.7	413	119	554	160	1 5/8 × 1 5/8	-	034G7803*)	034G7813*)		

¹⁾ The above estimated capacities, are based on the following conditions:
 Evaporating temperature t_e : 5 °C / 40 °F
 Liquid temperature t_l : 28 °C / 82 °F
 Condensing temperature t_c : 32 °C / 90 °F
 Full stroke opening in normal flow direction
 Capacity is ± 10% in full open state in reverse flow direction
 *) For flammable refrigerants contact Danfoss



Coolselector® 2

is a Danfoss calculation and selection software, designed to make selection processes for all refrigeration projects easier and less time consuming.
 For fast and precise selection of valve, use Danfoss' CoolSelector2® software.
 You can download it from <http://coolselector.danfoss.com>

Identification (laser engraved data)

- Made in Denmark : Country of origin
- Colibri® Electric Expansion valve : Valve name
- ETS XXXC : Valve type
- N0317A (Manufacturing no.) : N = Nordborg, Denmark
- 03 = week
- 17 = 2017
- A = Monday
- 10 Ω, 800 mA peak : Motor resistence, current
- PS 50 bar / MWP 725 psig : Max. working pressure
- 40/+70 °C / -40/+158 °F : Refrigerant temperature
- 034GXXXX : Code number
- CE, c, RU, US, 089 : Approvals
- QR code : QR code
- (with traceable serial no.) (with traceable serial no.)
- Danfoss, 6430 Nordborg, Denmark : Manufacturer address

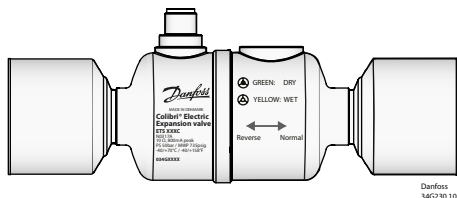

Valid for ETS 25C, ETS 50C, ETS 100C

Accessories:
M12 angle cable

M12 angle female connector is intended for use with a standard M12 male connector, available on stepper motor valves.
This cable is designed to offer high flexibility and small outer diameters with tensile strength. The angle way M12 cable consist of paired, twisted wires, which decreases mutual influence between signals transmitted along the cable and reduces influence of external sources of interference. The cables thus provides a higher degree of protection against lost steps compared to other cables.

Approvals for cable



Specification

Jacket	PVC - black
Cable outer sheath	Oil - resistant
Water proof rating	IP 67
Operating temperature range	-40 – 80 °C
Wire type	Twisted pair, cross section 20 AWG / 0.5 mm ²
Cable outer diameter	7.0 mm
Minimum bending radius	10 x cable diameter
Cable combustibility / test	Flame retardant / VW-1 / CSA FT - 1
M12 standard	EN 61076-2-101
Reference standard	UL style 2464 and DIN VDE 0812
LVD directive	2014/35/EU

Ordering



Cable	Cable length (L)	Insulation	Packing format	Code no.
PVC - black	2 m / 6.6 ft	SR-PVC	Single pack	034G7073
	8 m / 26.2 ft	SR-PVC	Single pack	034G7074

Identification

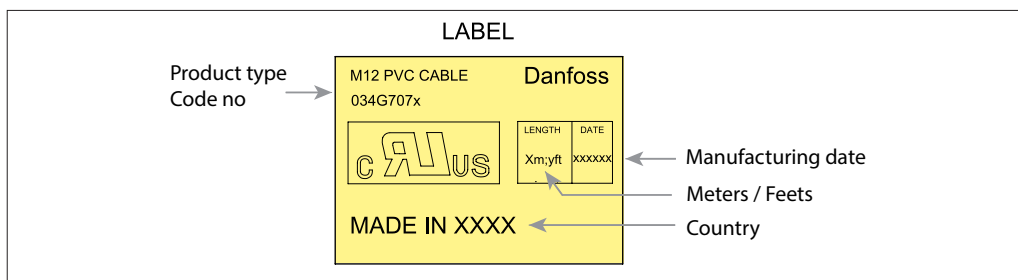

Connections

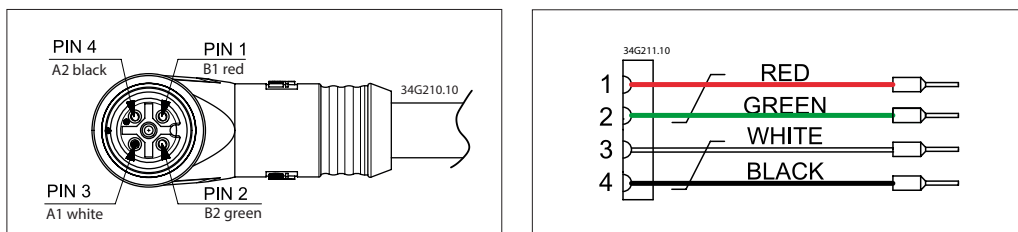

Dimensions

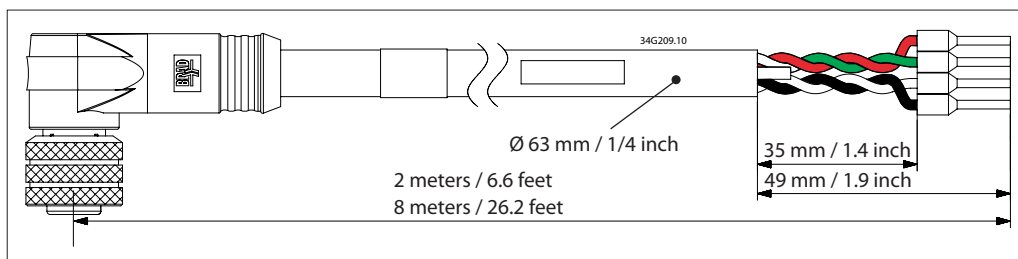

Design and function

The ETS Colibri® in-line electronic expansion valve regulates refrigerant flow by means of an internal cage slider which moves in a linear motion. This occurs by the rotation of a spindle assembly which moves when electrical pulses are applied to the motor. The direction of the rotation of the spindle depends on the phase relationship of the power pulses.

The valve design is pressure balanced, giving identical bi-flow performance capabilities and nearly identical maximum capacities. Operating the ETS Colibri® series requires a controller that can provide 800mA peak/ 600mA RMS current per phase in order to achieve the operational temperature and MOPD envelope of the valve.



Cable length

Depending on the type of controller or driver, there will be limitations in cable length between the controller / driver and the valve. Both the actual cable length, the level of EMC emission on the location and the driver circuit have an impact on the actual distortion of the current to the motor. On using 3rd party longer cable, make sure that the valve receives the exact current as defined in the specification.

- 1. Valve body in stainless steel
- 2. Connections in bi-metal
- 3. Sight glass with moisture indicator
- 4. M12 electrical connection
- 5. Stepper motor
- 6. Cage and slider

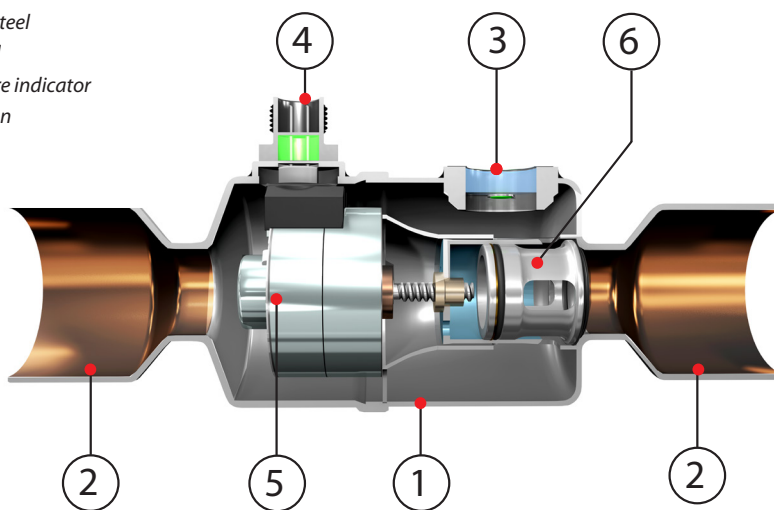

Flow direction

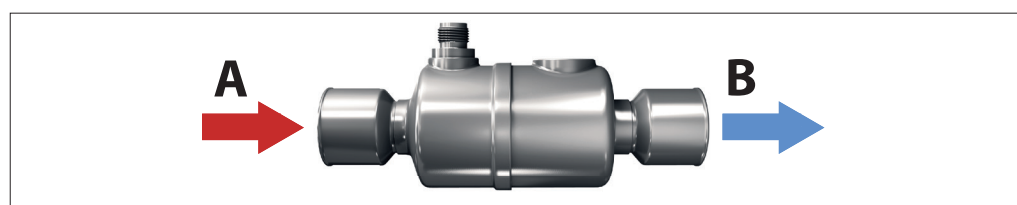

Flow direction from A to B refers the normal flow.
Sightglass for flash gas detection can only be used in normal flow direction.

Valve design

Sight glass and indicator

ETS 25C, ETS 50C and ETS 100C have integrated sight glass with moisture indicator. The presence of the sight glass provides the availability to check the physical position of the slider in the valve. It also helps to determine the flow direction of the refrigerant in the system. Insufficient sub cooling can produce flash gas which is visible through the sight glass. The moisture indicator in the sight glass indicates dry or wet state of the refrigerant by changing colour.

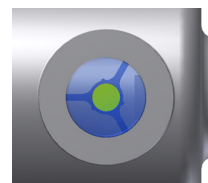

- Moisture indicator
- Green = dry
- Yellow = wet

Valve opening position
(Valid for ETS 25C - ETS 100C)

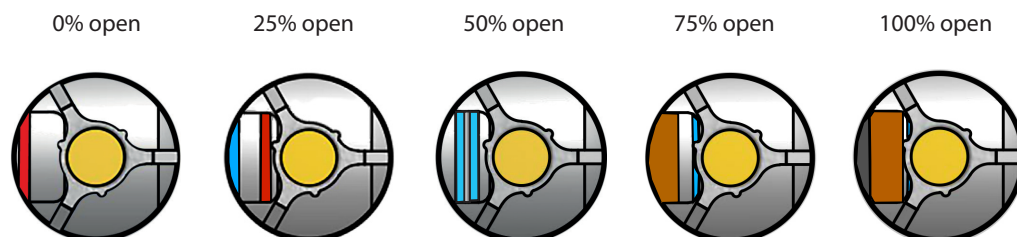
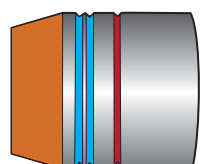

The colors of the grooves are only for illustration purposes

Flow curve

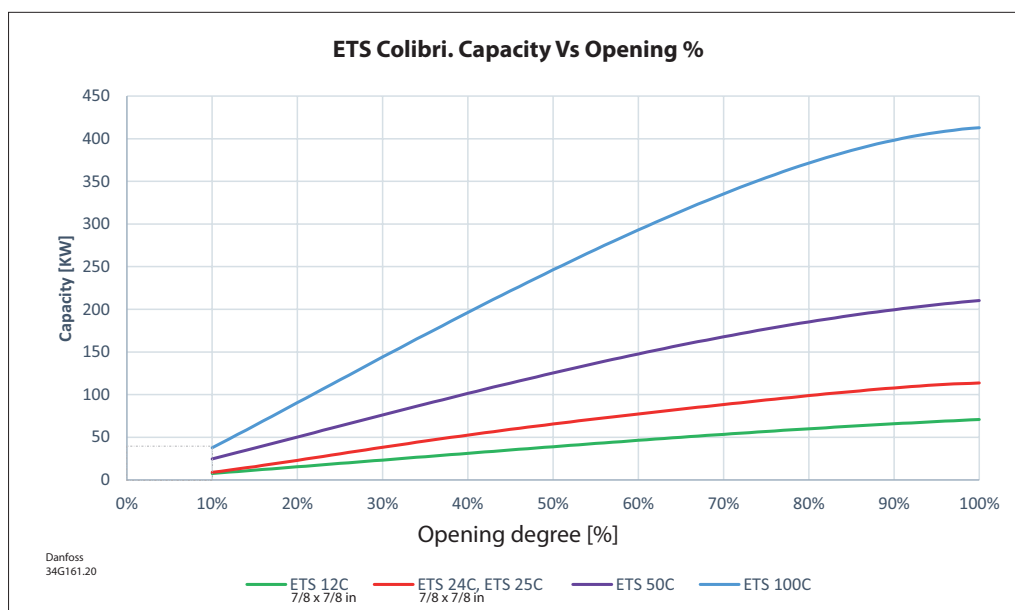

For R134a

The above estimated capacities, are based on the following conditions:
 - Evaporating temperature t_e : 5 °C / 40 °F
 - Liquid temperature t_l : 28 °C / 82 °F
 - Condensing temperature t_c : 32 °C / 90 °F
 Full stroke opening in normal flow direction. Capacity is \pm 10% in full open state in reverse flow direction.

Driving Colibri® valve

ETS Colibri valves use a bipolar, 2-phase, permanent magnet stepper motor. ETS valves can be driven using various electronic control techniques i.e: Full step excitation mode, half step excitation mode, micro stepping mode (recommended). On selecting controller from other manufacturer than Danfoss, it is necessary to set the following correct valve data into the controller setting. The wrong settings may impair the performance of the valve.

- Total no. of steps
- Step rate
- Phase current
- Overdriving against closing position



If the controller driving the ETS Colibri valve is from another manufacturer than Danfoss or a custom design, the following points must be considered in order to overcome potential step loss. To ensure total closing of the valve, and to compensate the lost steps after a defined number of changes in opening degree the controller should have a function to overdrive the valve in the closing direction. It is recommended to overdrive the valve at appropriate intervals as specified in the specification table.



At power failure the ETS valve will remain in the actual opening position it has at the moment of power failure, unless a device in the form of a battery backup to the controller is installed.

Stepper motor switch sequence

The following table shows the full step excitation switching sequence

	Pin	Coil A		Coil B		
		A 1	A 2	B 1	B 2	
	Wire color	White	Black	Red	Green	
	STEP					
CLOSING ↓	1	+	-	+	-	OPENING ↑
	2	+	-	-	+	
	3	-	+	-	+	
	4	-	+	+	-	
	1	+	-	+	-	

Color code is only valid for Danfoss M12 cable

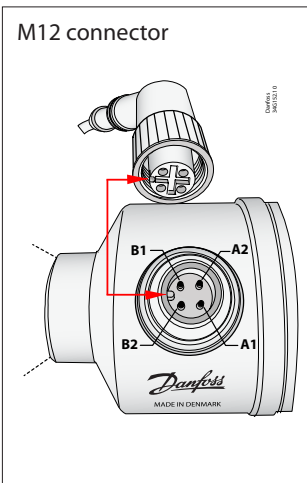

Electrical check of stepper motor and wiring: coil A and coil B = 10 Ω at 20 °C / 68 °F

Operation principle

This section explains the operation of the two phase full step excitation method in a bipolar stepper motor. Fig. 1 shows the simplified diagram of a rotor and a stator. The Full stepping operation is summarized below.

When a current in a form of a pulse flows to a given phase, that phase of the stator is excited as shown in Fig. 2.

1. On exciting Phases B1 and A1 simultaneously, the permanent magnets on the rotor are moved in the intermediate position between phase B1 and phase A1
2. When phases A1 and B2 are excited simultaneously, the rotor is then positioned between phases A1 and B2
3. Next, by exciting the successive adjacent pairs of phases sequentially i.e phases B2 and A2, phases A2 and B1, and phases B1 and A1, the rotor rotates through two phase excitations
4. By completely reversing the cycle in the following sequence phases B1 and A1 to phases A2 and B1 to phases B2 and A2 to phases A1 and B2, the stepper motor then reverses its rotation
5. The stepper motor is stopped by holding the phase excitation for a specified period at the last phase of forward or reverse rotation

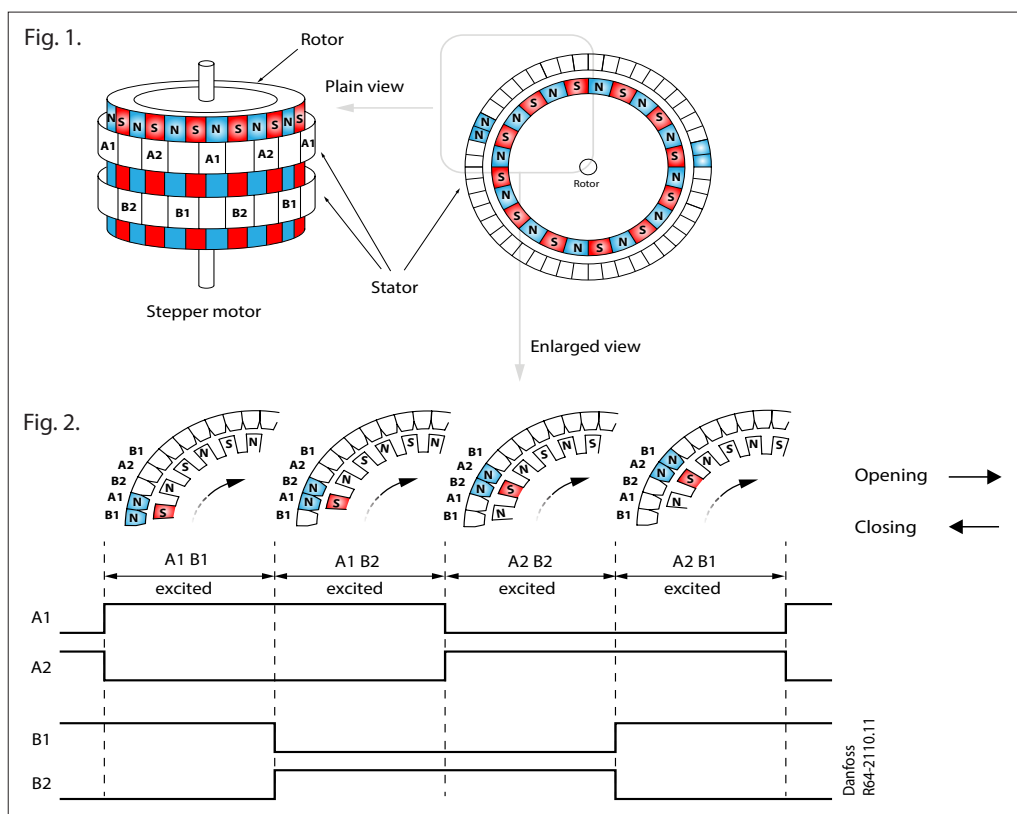

Two phase full step excitation



ETS Colibri valves can also be driven by micro stepping excitation method (preferred) in addition to the one explained above.

Dimensions
ETS 12C / ETS 24C

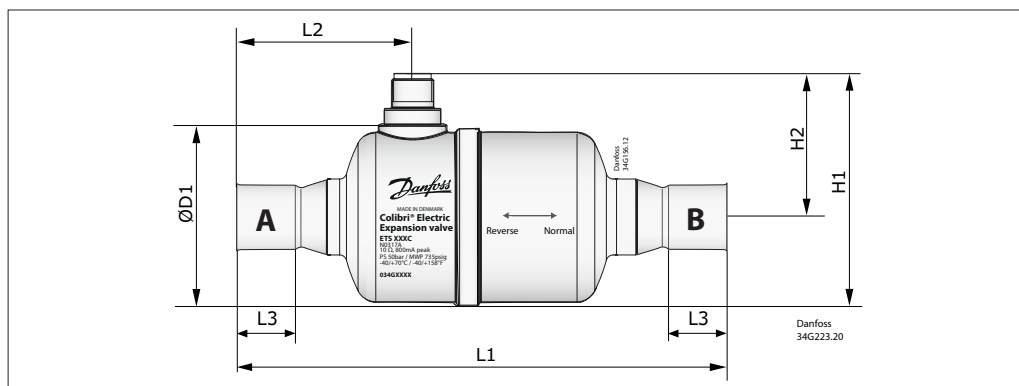

Type	Connections ODF x ODF (A x B)	ØD1		L1		L2		L3 min		L4 min		H1		H2		Code no. *)
	[in]	[mm]	[in]	[mm]	[in]	[mm]	[in]	[mm]	[in]	[mm]	[in]	[mm]	[in]	[mm]	[in]	
ETS 12C	1/2 x 1/2	49.9	2	122	4.8	41.6	1.6	9.5	0.3	9.5	0.3	65.6	2.6	40.7	1.6	034G7500
	5/8 x 5/8	49.9	2	132	5.2	46.6	1.8	14.7	0.6	14.7	0.6	65.6	2.6	40.7	1.6	034G7501
	7/8 x 7/8	49.9	2	135	5.3	48.4	1.9	20.0	0.8	20.0	0.8	65.6	2.6	40.7	1.6	034G7502
ETS 24C	1/2 x 1/2	49.9	2	122	4.8	41.6	1.6	9.5	0.3	9.5	0.3	65.6	2.6	40.7	1.6	034G7900
	5/8 x 5/8	49.9	2	132	5.2	46.6	1.8	14.7	0.6	14.7	0.6	65.6	2.6	40.7	1.6	034G7901
	7/8 x 7/8	49.9	2	135	5.3	48.4	1.9	20.0	0.8	20.0	0.8	65.6	2.6	40.7	1.6	034G7902

*) For the equivalent industrial packed code number see the ordering section

**ETS 25C, ETS 50C and
ETS 100C**

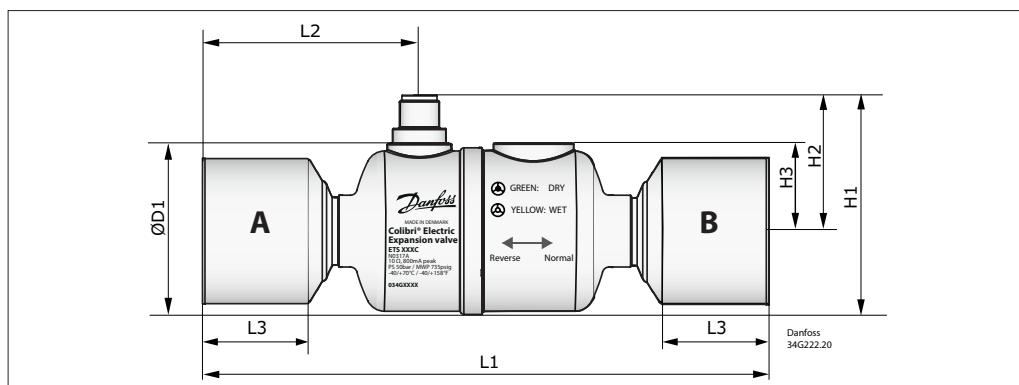

Type	Connections ODF x ODF (A x B)	ØD1		L1		L2		L3 min		L4 min		H1		H2		Net weight [kg]	Code no. *)
	[in]	[mm]	[in]	[mm]	[in]	[mm]	[in]	[mm]	[in]	[mm]	[in]	[mm]	[in]	[mm]	[in]		
ETS 25C	7/8 x 7/8	49.9	2	135	5.3	48.4	1.9	20	0.8	20	0.8	65.6	2.6	40.7	1.6	0.31	034G7602
ETS 50C	7/8 x 7/8	49.9	2	135	5.3	48.4	1.9	20	0.8	20	0.8	65.6	2.6	40.7	1.6	0.31	034G7700
	7/8 x 1 1/8	49.9	2	137	5.4	48.4	1.9	20	0.8	20	0.8	65.6	2.6	40.7	1.6	0.32	034G7701
	1 1/8 x 1 1/8	49.9	2	139	5.5	50.4	2	20	0.8	20	0.8	65.6	2.6	40.7	1.6	0.32	034G7702
ETS 100C	1 1/8 x 1 3/8	49.9	2	147	5.8	50.4	2	20	0.8	25	1.0	65.6	2.6	40.7	1.6	0.33	034G7703
	1 1/8 x 1 1/8	49.9	2	139	5.5	50.4	2	20	0.8	20	0.8	65.6	2.6	40.7	1.6	0.32	034G7800
	1 1/8 x 1 3/8	49.9	2	147	5.8	50.4	2	20	0.8	25	1.0	65.6	2.6	40.7	1.6	0.33	034G7801
	1 3/8 x 1 3/8	49.9	2	155	6.1	58.4	2.3	25	1.0	25	1.0	65.6	2.6	40.7	1.6	0.35	034G7802
	1 5/8 x 1 5/8	49.9	2	169	6.7	65.4	2.3	30	1.2	30	1.2	65.6	2.6	40.7	1.6	0.37	034G7803

*) For the equivalent industrial packed code number see the ordering section

Troubleshooting

Symptom	Possible Cause	Remedy
No valve movement	Lack of proper electrical connection	• Check the connection between valve and a controller
	Wrong parameter setting in controller	• Check valve settings in controller i.e pre-selected valves, no. of steps, phase current, direction of valve rotation, steps per second
	Broken motor/ short circuit	• Check the resistance between coil A and coil B. Resistance in each coil should be 10 ohms @20°C. Details on page 4 • Replace a complete valve
	Insufficient power supply to valve	• Check the current/voltage supply from controller to valve
Internal leakage (due to 'Step Loss')	Control pulse to valve is influenced by high external electrical noise	• Separate the cable from high power lines
	Longer cable length between valve and controller	• Check the maximum cable length allowed between the controller and the valve • For longer cable distance, use cable with bigger wire diameter • Use cable filter
	Accumulated backlash in valve	• Controller should overdrive the valve to compensate the lost steps after a number of changes in opening degree
	Insufficient power supply to the valve	• Check the current/voltage supply from controller to valve • Check the supply power to controller
Insufficient capacity	Expansion valve too small	• Check refrigeration system capacity and compare with expansion valve capacity. Replace with larger valve if necessary
	Suction pressure too low Evaporator superheat too high	• Check superheat performance, the settings SH min and SH max. in the super heat controller • Check valve capacity • Check 'total number of steps' defined in the controller • Also check section 'High Superheat'
	Expansion valve blocked with foreign material	• Remove and examine the valve
	Evaporator wholly or partly iced up	• De-ice evaporator
High superheat	Lack of sub-cooling	• Check refrigerant • Also refer to section Insufficient capacity
	Controller is not setup/tuned properly	• Check the controller superheat settings and sensors connected to it • Tune PID parameters in the controller
Flash gas	Lack of sub-cooling ahead of expansion valve	• Check refrigerant for flash gas ahead of expansion valve / external subcooler • If the valve is placed much higher than condenser outlet, check pressure difference
	Oversized valve selected	• Limit max opening degree of the valve setting in controller • Check refrigeration system capacity and compare with expansion valve capacity. Use proper valve size suitable for the system

Related products (for more details, click the image below)

EKE 1A, EKE 1B, EKE 1C superheat controller	EKS 221, ACCPBT, AKS 11 / AKS 12 temperature sensor	AKS 32R, AKS 32, AKS 33, NSK pressure transmitter	Code no. 034G0013 AST-G service driver

All Danfoss products fulfill the requirements in REACH.

One of the obligations in REACH is to inform customers about presence of Candidate list substances if any, we hereby inform you about one substance on the candidate list:

A moist indicator in the sight glass contains a paper which is impregnated with Cobalt Dichloride (CAS no: 7646-79-9) in a concentration above 0.1% w/w.

Avoid skin contact with the paper - Do not inhale the dust from the paper - The paper must be disposed as hazardous waste.

Danfoss can accept no responsibility for possible errors in catalogues, brochures and other printed material. Danfoss reserves the right to alter its products without notice. This also applies to products already on order provided that such alterations can be made without consequential changes being necessary in specifications already agreed. All trademarks in this material are property of the respective companies. Danfoss and the Danfoss logotype are trademarks of Danfoss A/S. All rights reserved.